

You are in the bank when armed robbers take over. They are about to execute the first hostage when you go into action.

Start Position: P1. Hands naturally at sides

Stage Procedure	Notes	
On signal, draw and engage plate S1 until it falls. Plate activates clamshell. Engage T2 and T3 with 2 rounds in any order. Then move to P2 and engage plate S2, then T4 and T5 with two rounds, any order. You must fire at least one round on T3 as it falls. If not satisfied, you may use cover at P3 to finish T3.	Scoring Rounds Distance Start - Stop Concealed Carry	IDPA, Vickers 10 Min 7 to 10 yds Audible - Last Shot Yes

Note: A gun malfunction while T3 is dropping does not earn a penalty.

Safety Officers: Matt Sims & Ron Holland

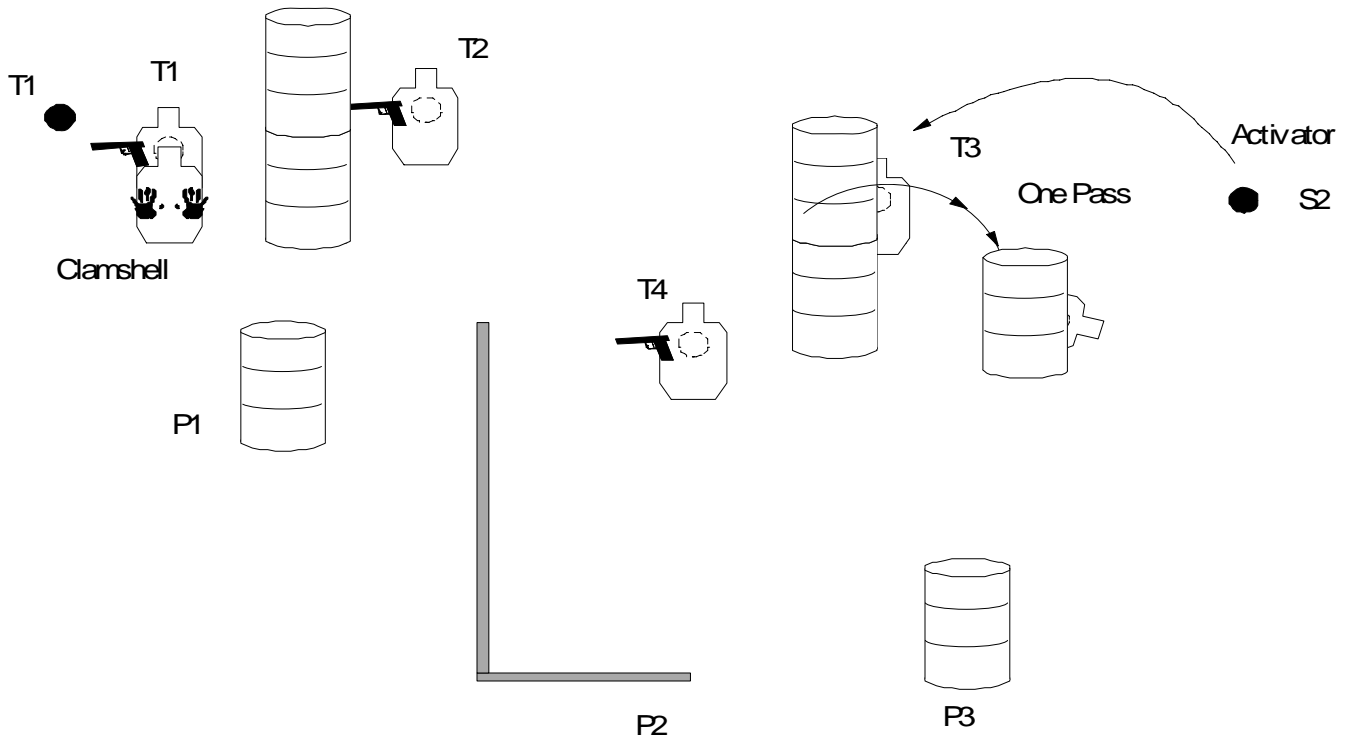

Bay 2 Stage 2
Keep Those Mags Full
 Course Designer: Joe Day

Start Position: Seated in chair at P1, cleared gun in box, 6-round mag on table, two six-round mags on belt, rope in strong hand..	
Stage Procedure	Notes
At start signal pull rope, then retrieve and load gun. Engage T1 while seated. The rest are shot from cover. All targets must be neutralized.	Scoring Vickers Rounds 15 Distance 3-20 yds Start - Stop Audible - Last Shot Concealed Carry NA

Safety Officers: Joe Day, Audrey Day, & Chris Stewart

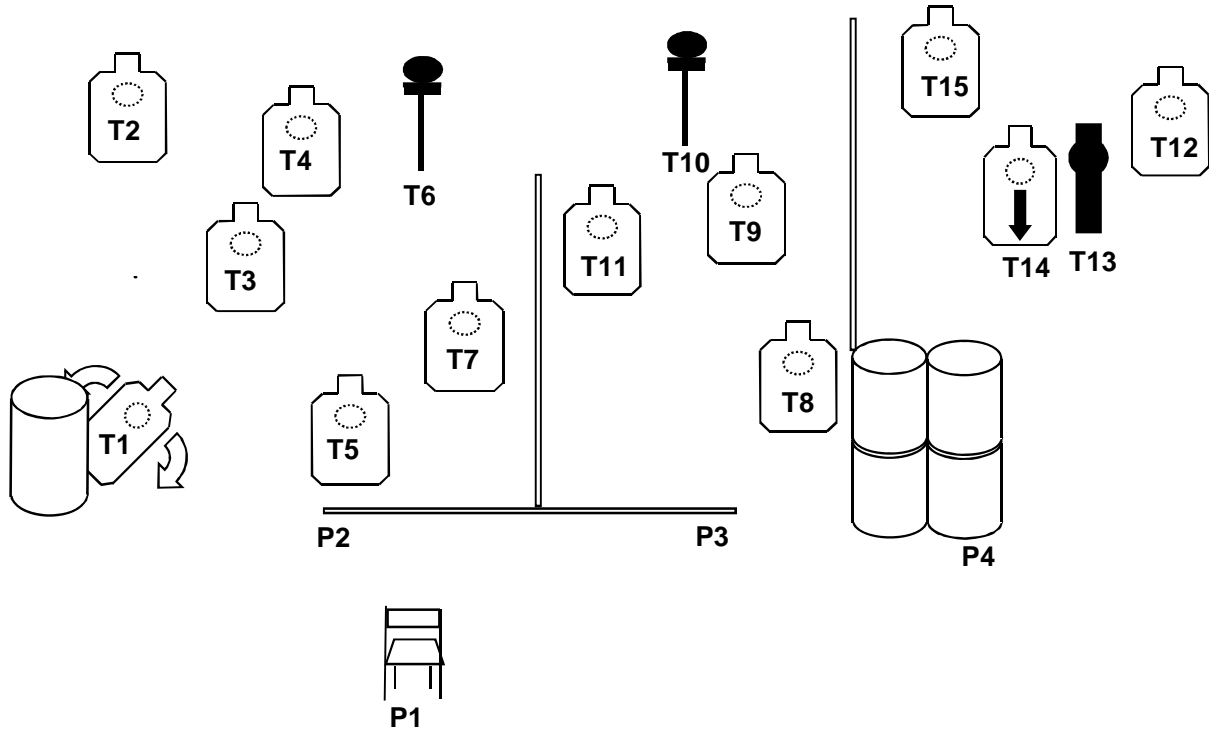

Bay 3 Stage 3

Shoot The Alley

Designed by Joe Day

Start Position: P1 gun holstered	
Stage Procedure	Notes
At start signal engage T1, T2 & T3 from cover. T4 & T5 may be shot while moving to P2 or from cover.	Scoring Vickers Rounds 14 Distance 5-18 yds. Start - Stop Audible - Last shot Concealed Carry Yes

Safety Officers: Joe Day, Audrey Day, & Chris Stewart

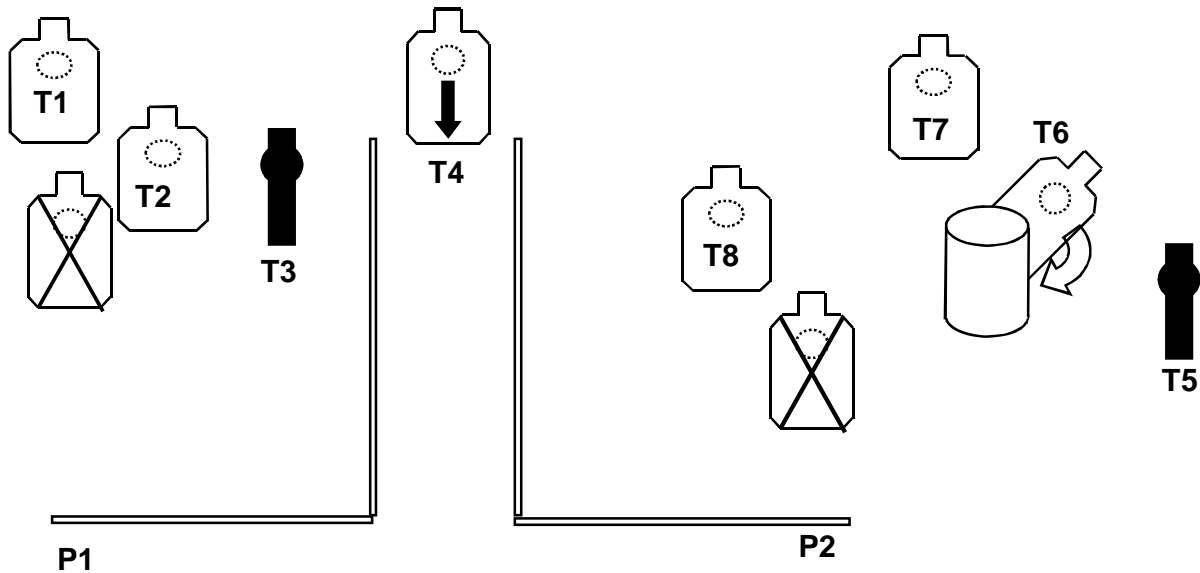

You are attacked in a parking lot. You eliminate the first two threats and take cover behind an SUV. Two more BG's engage you and three more take cover and begin firing. You can engage from where you are or move to the other end of the SUV for a better shot.

Start Position: P1. Hands naturally at sides	
Stage Procedure	Notes
On signal, draw and engage T1 and T2 with 2 rounds while moving to cover at P2. From P2 engage T3 and T4 with 2 rounds each. Engage T5-T6 from P2 or P3 with 2 rounds each. Any IDPA legal reload is ok between P2 and P3.	Scoring Rounds Distance Start - Stop Concealed Carry
Note: You must go to P2 FIRST. P3 is optional.	IDPA, Vickers 14 Min 5 to 20 yds Audible - Last Shot Yes

Safety Officers: Jimmy Duke & Chris Donald

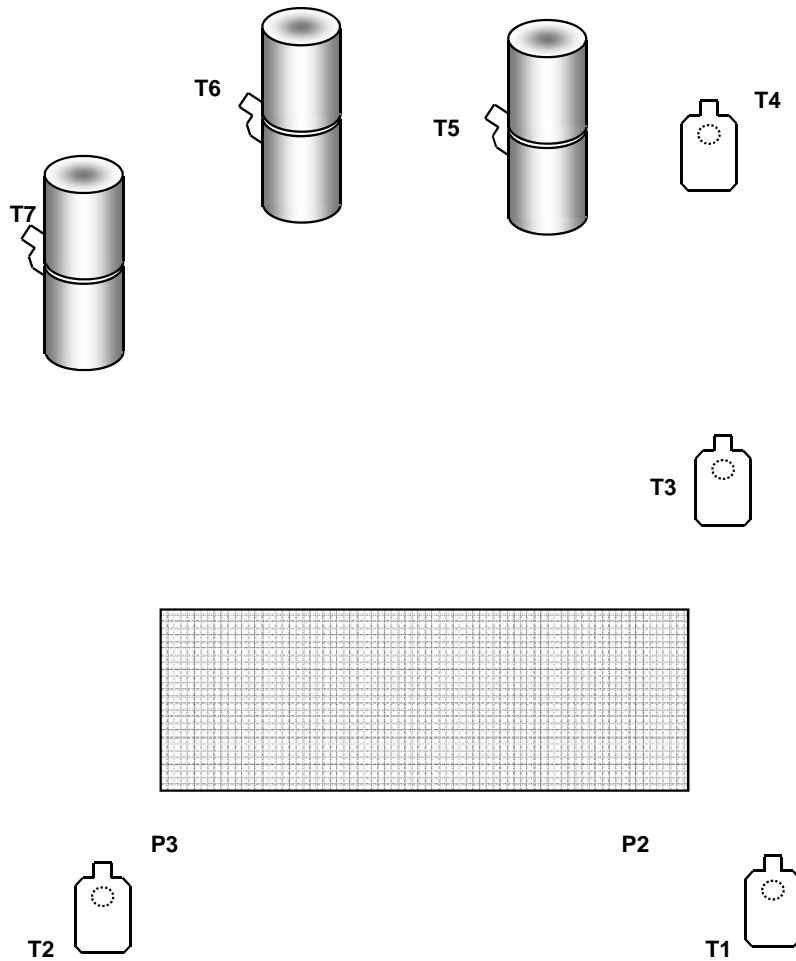

Identify the Threats

Designed by Ron Holland

Gangsters have hostages. They plan to add you to their list of victims. When detracted, you move.	
Start Position:	At P1. Shooter indicates ready by raising hands above shoulders.
Stage Procedure	Notes
From P1, you may engage the targets in the order of your choosing, either standing or while moving. Paper gets two, steel must fall. Move to P2 and engage the threats in tactical priority.	Scoring Vickers Rounds 10 Min Distance 4 - 10 Yards Start - Stop Audible - Last Shot Concealed Carry Yes

Safety Officers: Jimmy Duke & Chris Donald

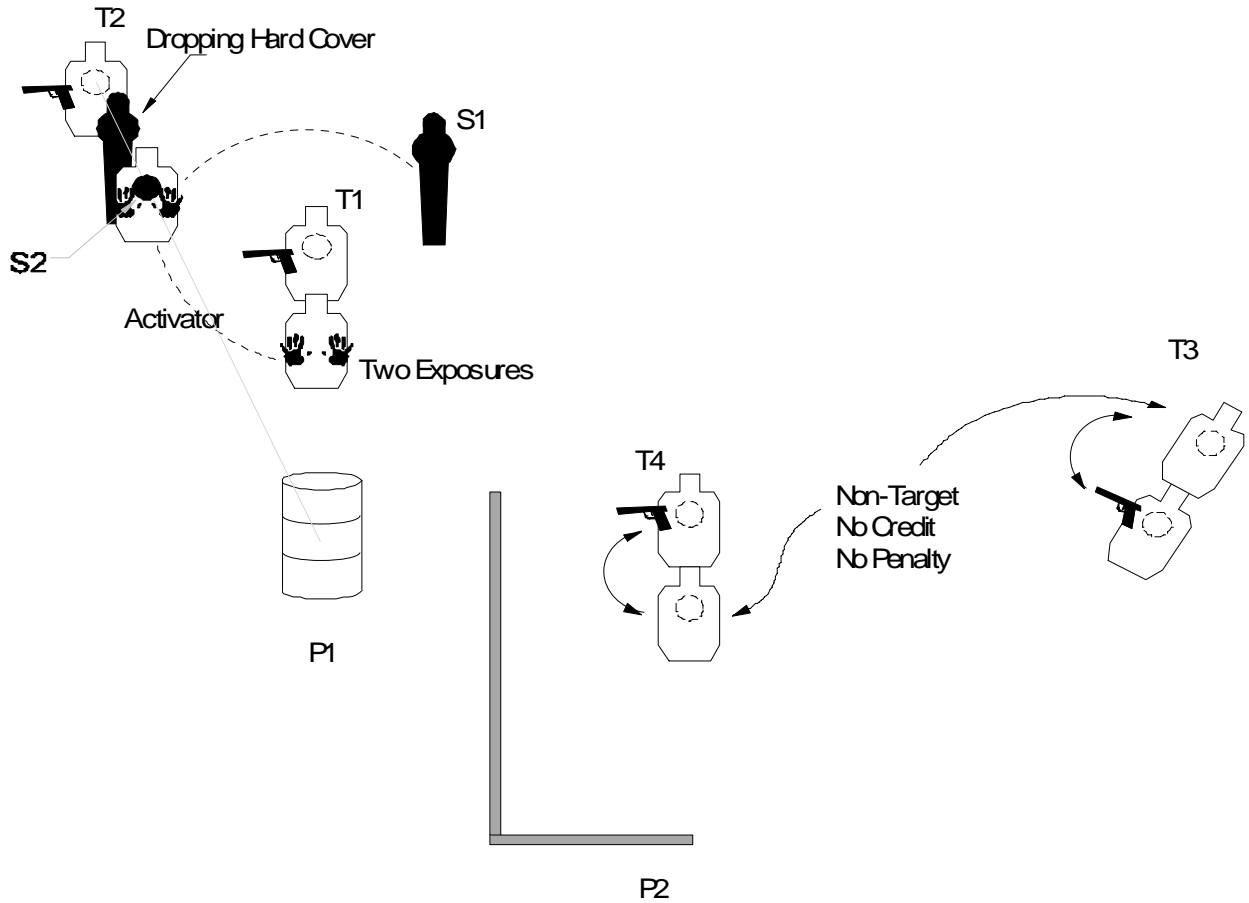

You are confronted by BGs. After the initial confrontation, they take a hostage. You must rescue.	
Start Position: Standing at P1, butt to barrel. Hands hanging naturally at sides, gun holstered.	
Stage Procedure	Notes
On signal, engage threats in tactical priority with two rounds each, either while moving or from cover at P2 or P3.	Scoring Vickers Rounds 12 Min Distance 5 - 12 Yards Start - Stop Audible - Last Shot Concealed Carry Yes

Safety Officers: Capel English & Brett Hanus

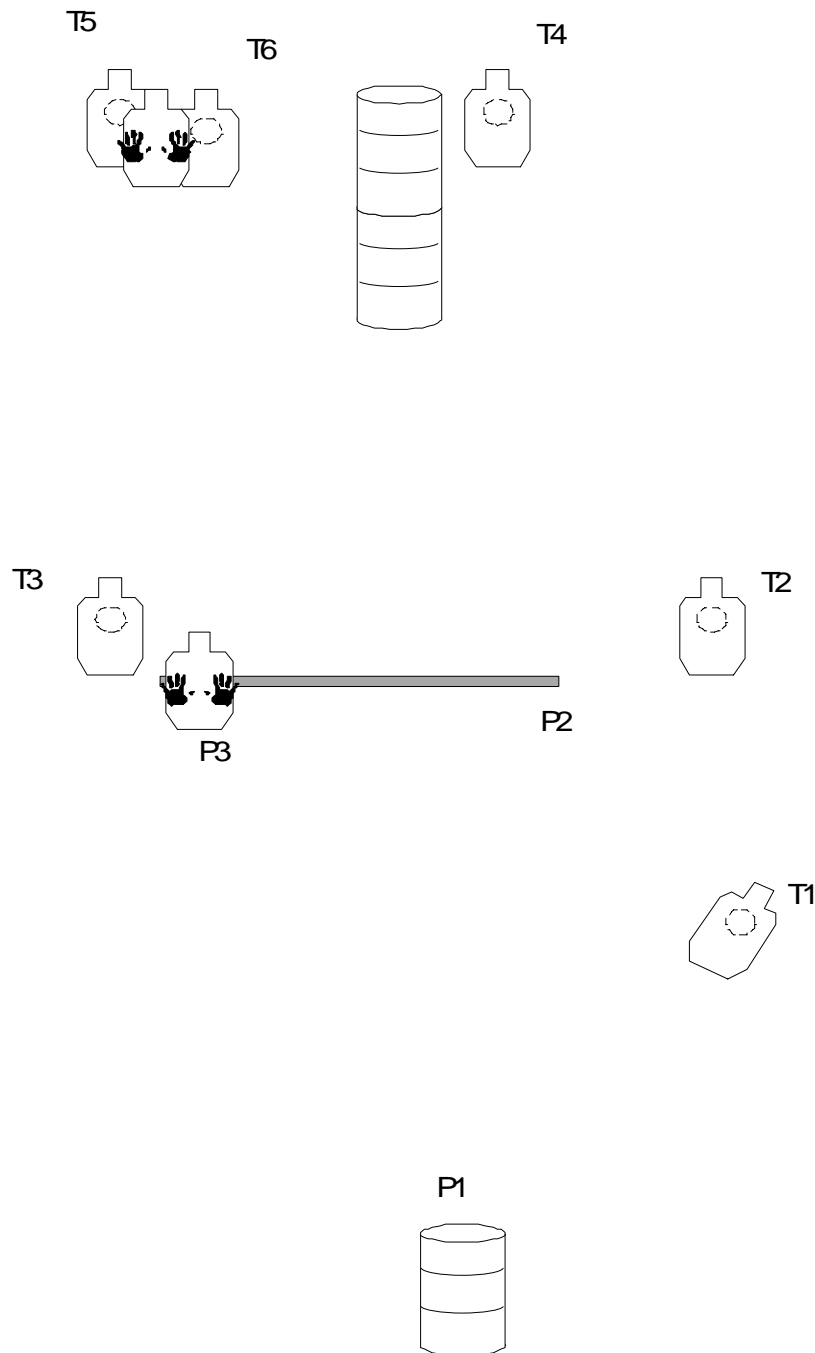

Parking Lot Action

Course Designer: Ron Holland

You are at a gas station for a refill when a gang of six attack. They grab your passenger to prevent a cell phone call for help. They indicate they are going to waste everyone at the station and set the gas station on fire - for fun. You take action to spoil their party.

Start Position: Standing at P1 in a "Fighting Stance". Gun holstered.

Stage Procedure	Notes
On signal, kick down the threat. Draw and engage T1, T2, and T3 with two rounds each. Move to P2 and use the car's rear windshield and roof for cover to engage T4, T5, and T6 with two rounds each.	Scoring Vickers Rounds 12 Min Distance 2 - 8 Yards Start - Stop Audible - Last Shot Concealed Carry NA

Safety Officers: Capel English & Brett Hanus

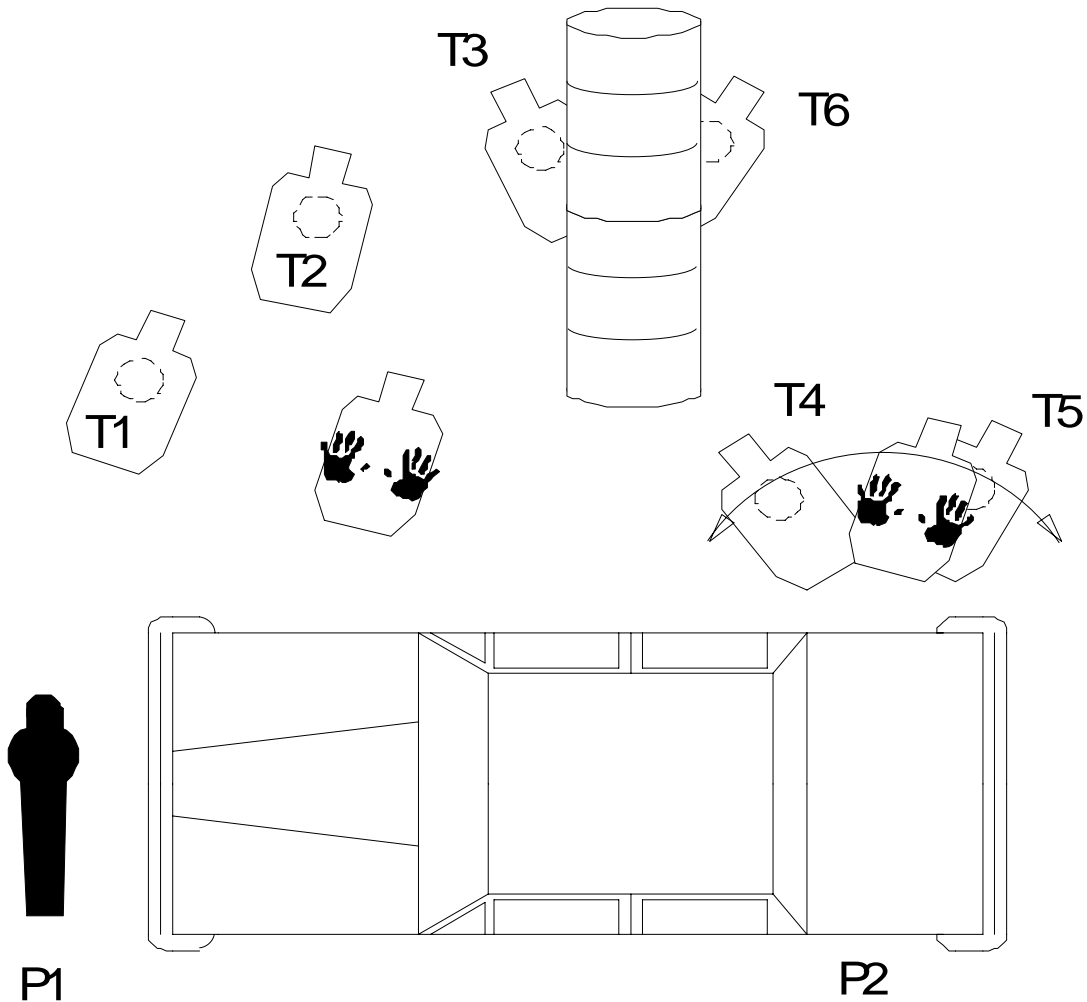

Bad Guys come to your barbeque.		
Start Position:	Standing at P1 with spatula in strong hand facing grill.	
	Stage Procedure	Notes
On signal turn draw and engage T1. Engage all other targets with two rounds as you see fit (on move or from cover).		Scoring IDPA, Vickers Rounds 16 Min Distance 3 to 10 yds Start - Stop Audible - Last Shot Concealed Carry Yes

Safety Officers: Randy Robinson & Guido Masters

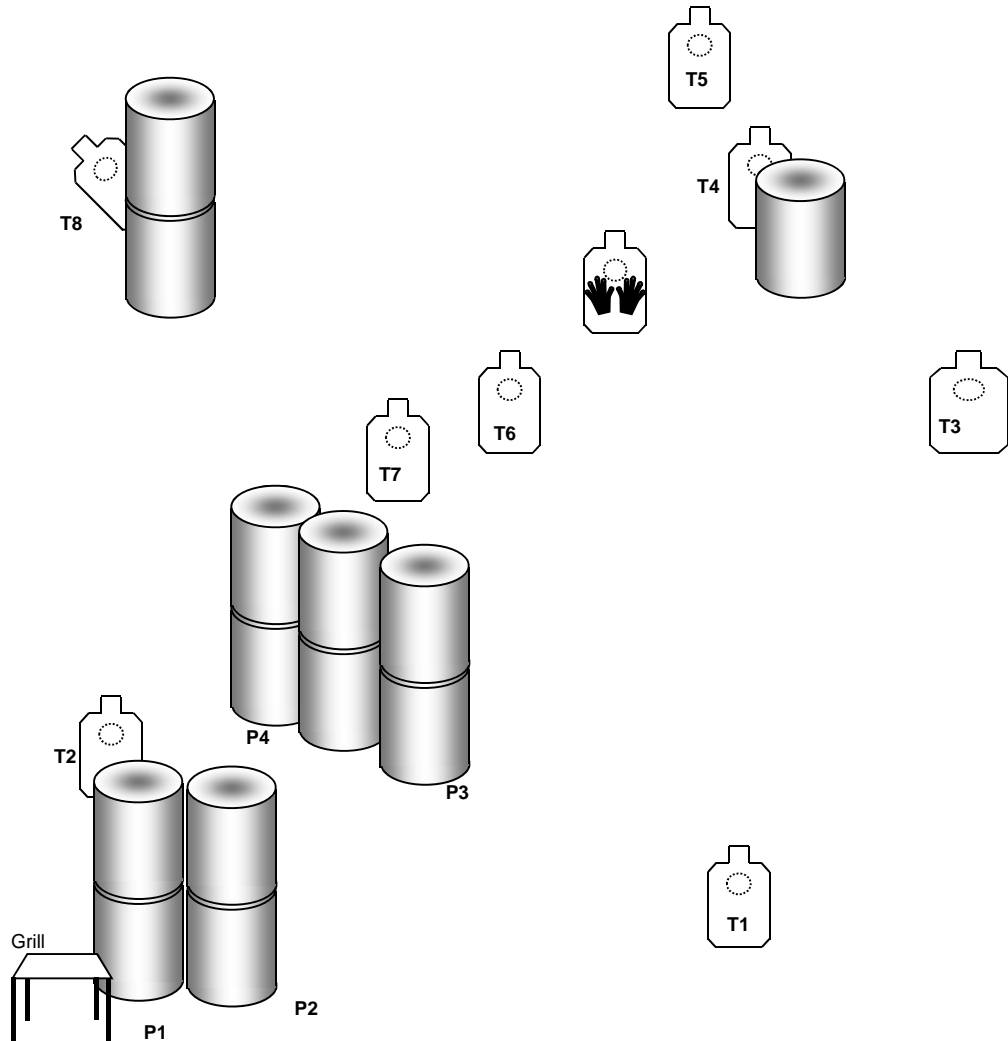

Scenario description...	
Strong hand/weak hand, movement, etc.	
Start Position: Standing at P1, hands at sides.	
Stage Procedure	Notes
On signal, engage T1 thru T3 while moving to cover at P2. Engage T4 thru T6, ONE hand only (your choice), tactical priority from P2 or while moving to cover at P3. Engage T7 thru T9, OPPOSITE hand only, tactical priority, from cover at P3 or while moving to cover at P4.	Scoring IDPA, Vickers Rounds 18 Min Distance 3 to 10 yds Start - Stop Audible - Last Shot Concealed Carry Yes
DON'T GET CAUGHT WITH AN EMPTY GUN. Reload positions are at cover P2, P3, and P4.	

Safety Officers: Randy Robinson & Guido Masters

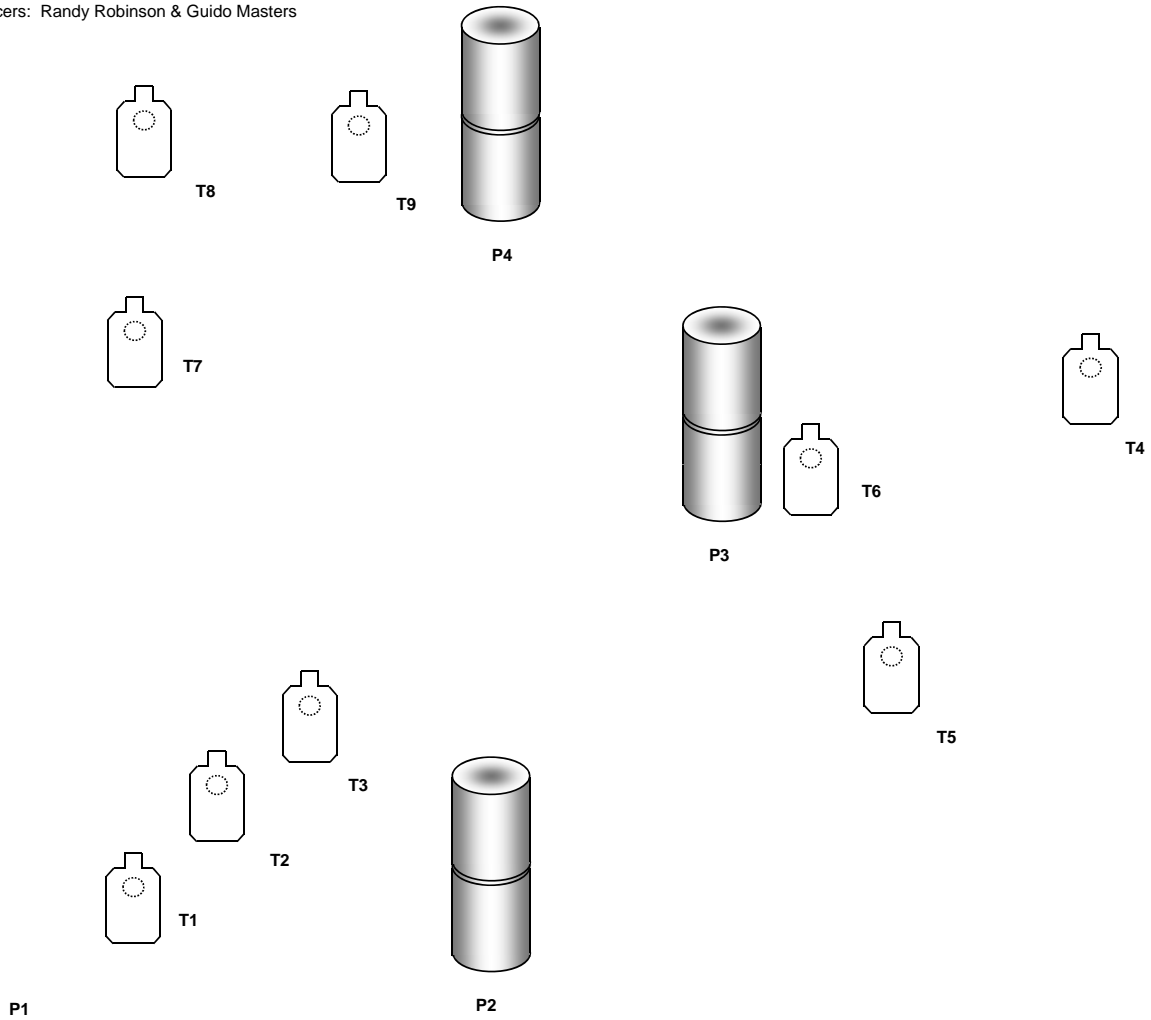

7-11 Holdup

Course Designer: Ron Holland

You are caught working behind the counter at the local 7-11 when three gangsters attempt a murder. You shoot them to their knees, then have to finish with head shots.

Start Position: Stranding at P1, one palm on each drum. Gun loaded to IDPA capacity.

Stage Procedure	Notes	
On signal, engage the standing threats with two rounds each. Take cover behind drums and engage the kneeling threats with two rounds in tactical priority from side of drum. Go prone on opposite side of drums and engage the prone targets from cover in tactical priority with one round to the head.	Scoring	Limited Vickers
	Rounds	15
	Distance	7 Yds
	Start - Stop	Audible - Last Shot
	Concealed Carry	Yes

Safety Officers: Stand Smith & Scott Randolph

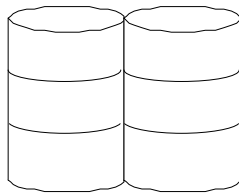
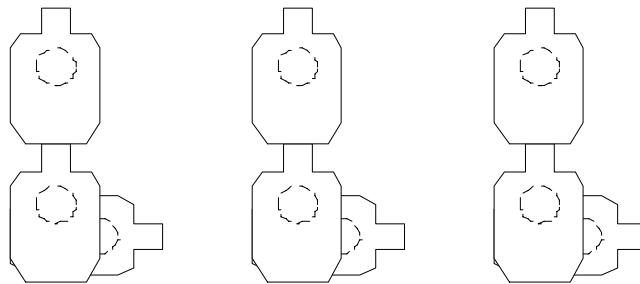

P1

Midnight Dream

Stage Design: Ron Hollanc

It went bump in the night. You get up to investigate. As you pause in the hall way, you hear screams from the adjoining room. You immediately respond. You must clear the house and yard of bad guys.

Start Position: Standing at P1 with heels even with door threshold. Gun at low ready.

Stage Procedure	Notes
<p>On signal, step back out of the hall and engage each threat from cover with a minimum of one round. You may start on the left or right, then proceed down the hall until all threats have been engaged. The small port at P5 is optional - use it if you like.</p> <p>This stage requires a lot of movement. Be aware of your muzzle and finger!</p>	<p>Scoring Vickers Rounds 12 Min Distance 5 - 12 Yards Start - Stop Audible - Last Shot Concealed Carry Yes</p>

Safety Officers: Stand Smith & Scott Randolph

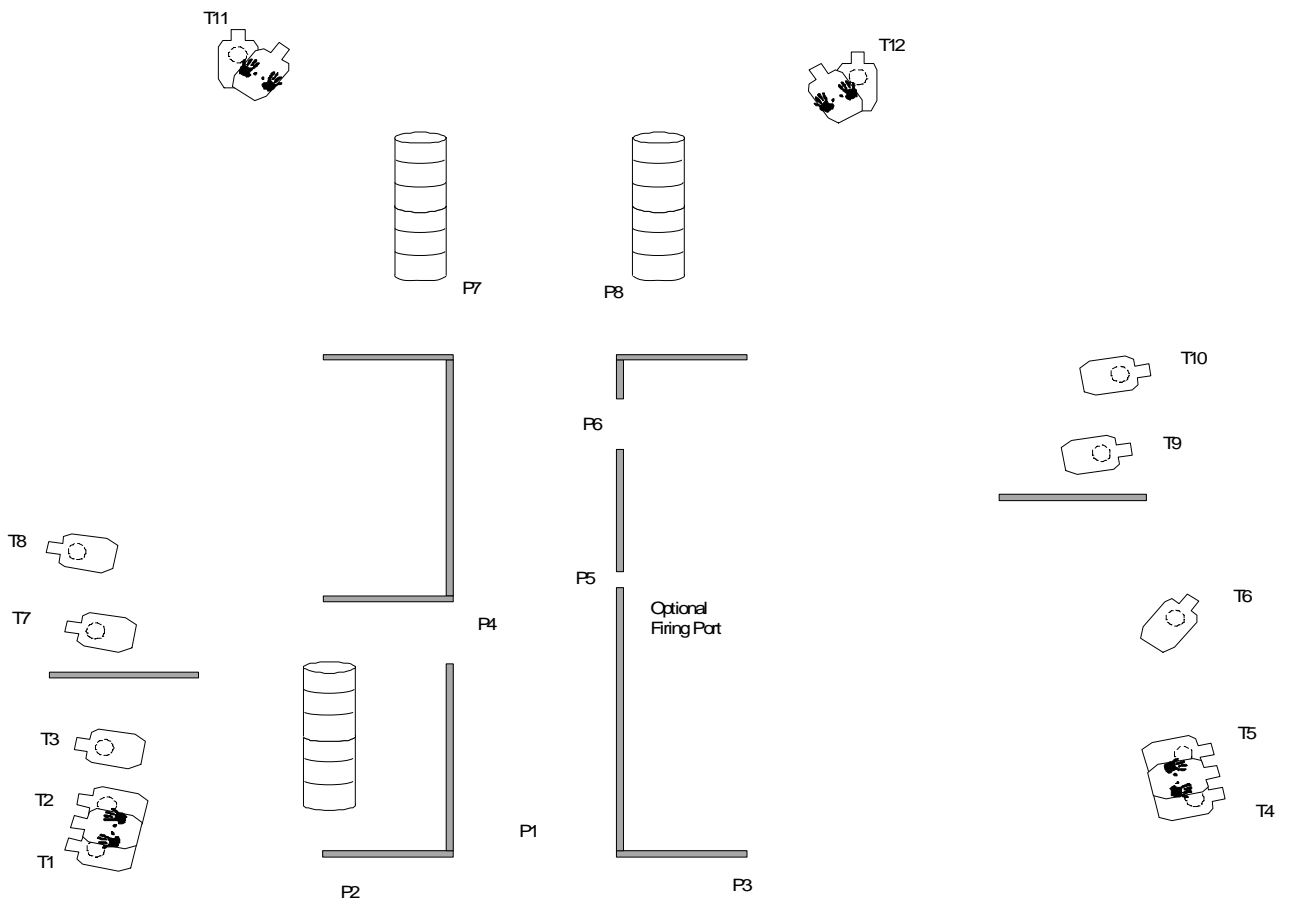

Scenario

You hear screams from the back yard. A gang of thugs is taking a shortcut through your back yard with their victim. Save the hostage.

Start Position: Hands naturally at sides, facing uprange, either side of doorway at P1 (your choice)

Stage Procedure

On signal, turn, then draw and engage targets with 2 rounds each. You may shoot from cover at the doorway, and/or shoot on the move advancing to P2 (your choice). From P2, finish the remainder of the targets from either side of P2 (your choice) in tactical priority. Don't get caught in the open with an empty gun.

Notes	
Scoring	IDPA, Vickers
Rounds	18 Min
Distance	3 to 20 yds
Start - Stop	Audible - Last Shot
Concealed Carry	Yes

Note: Reload positions are from cover at P1 or P2

Safety Officers: Mike Phillips & Wesley Nelson

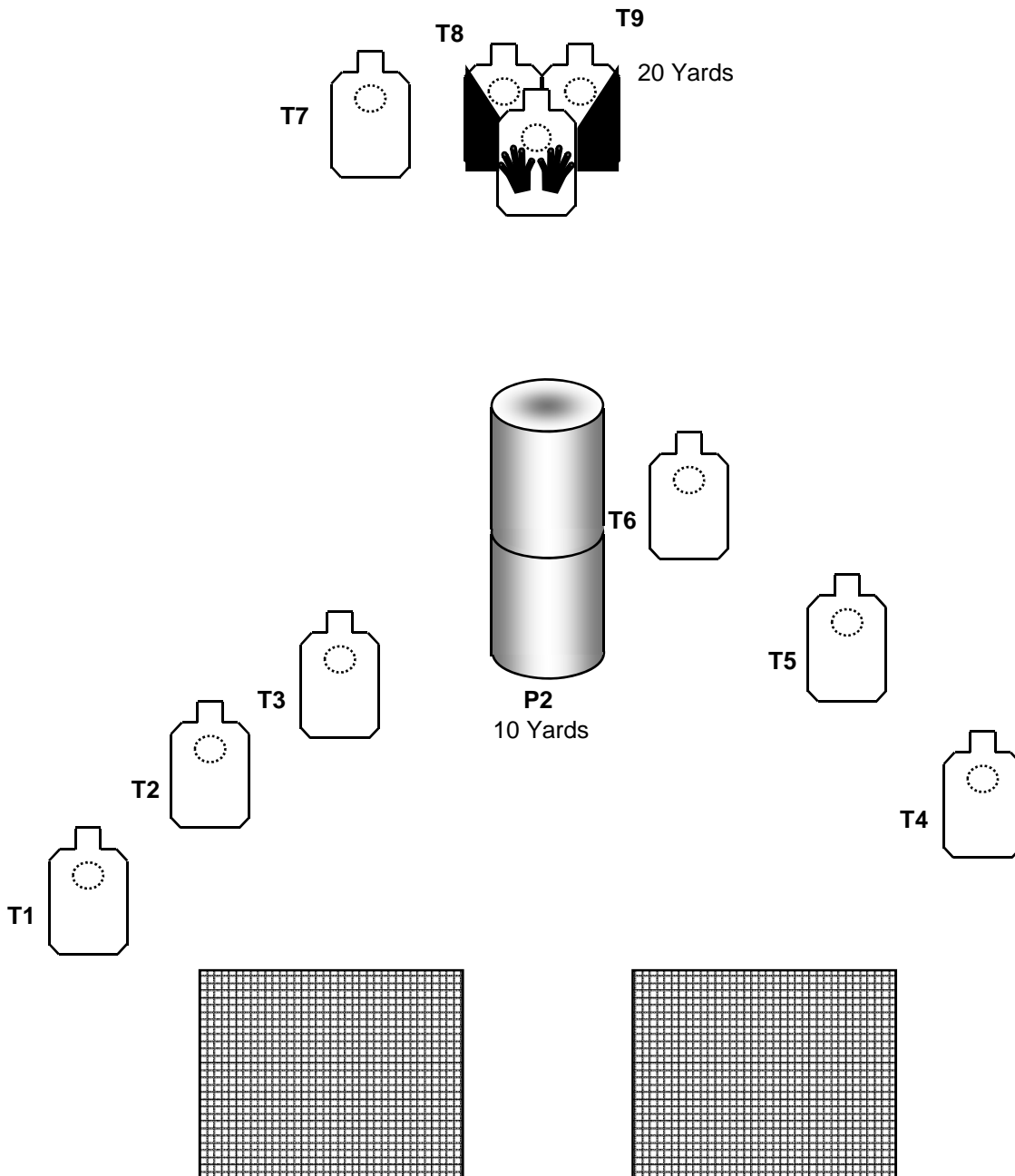

Scenario

You hear screams from the back yard. A gang of thugs is taking a shortcut through your back yard with their victim. Save the hostage.

Start Position: Hands naturally at sides, facing uprange, either side of doorway at P1 (your choice)

Stage Procedure	Notes	
On signal, turn, then draw and engage targets with 2 rounds each. You may shoot from cover at the doorway, and/or shoot on the move advancing to P2 (your choice). From P2, finish the remainder of the targets from either side of P2 (your choice) in tactical priority. Don't get caught in the open with an empty gun.	Scoring	IDPA, Vickers
	Rounds	18 Min
	Distance	3 to 20 yds
	Start - Stop	Audible - Last Shot
	Concealed Carry	Yes

Note: Reload positions are from cover at P1 or P2