

# The 2008 Masters

Bay F1

Stage 1

## Late Night Ambush

Course Designer: Mike Lunsford

**Scenario:** You're walking home late one evening when gang members attack you in the alley. You take out two drug crazed thugs and beat a hasty retreat. As you reach the end of the alley you notice more thugs hiding in the trees out back. You must decide if you want to take them out through a window in the fence because they are expecting you to appear at the other end of the fence. Take the head shots through the window or face them at the end of the fence, your choice. Since they are expecting you to emerge at P4 you decide to go low to confuse them. All shots from P4 must be from below the barricade, however you must still maintain cover.

**Start Position:** At P1 release ropes in both hands, arms hanging at sides.

**Stage Procedure:**

At the signal pull both ropes, draw and engage T1 and T2 with 3 shots each any order while retreating to P2. From P2 you may elect to bypass T3 and the activator as he is hiding with his back to you and doesn't see you come into view. Or, if you're feeling lucky you may engage the activator and T3 from cover at P2. There is no penalty for not dropping the steel activator. It is an **activator only** and not considered a threat. However, you must engage T4 from cover or while moving across to P3. You may elect to bypass the window at P3 and move on to P4 and engage T5 thru T7 from low cover. Shots on T3 can be made up from P4. T3 is NOT a disappearing target therefore will be scored as a failure to neutralize if not properly engaged. T1 and T2 will be scored for best 3 shots. All other threat targets will be scored for best 2 shots. All reloads to be IDPA legal.

**Notes**

Scoring	Vickers
Rounds	16 Min.
Distance	5 - 10 yds
Start - Stop	Audible - Last shot
Concealed Carry	Yes

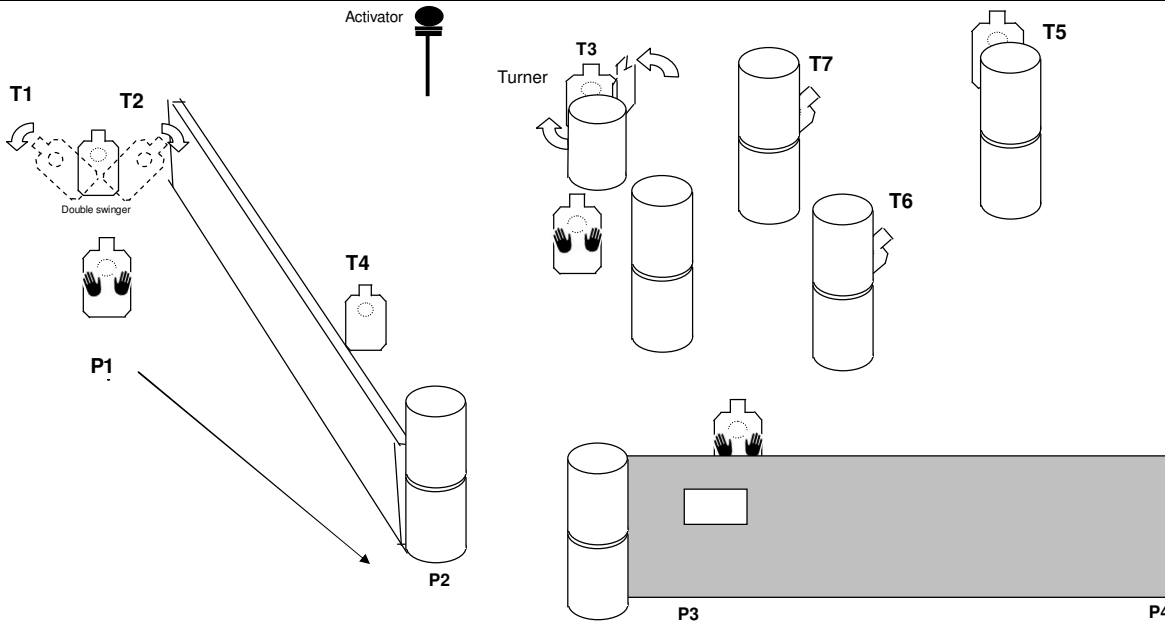

**Hit the Reload**

Joe Day

This scenario begins in the middle of a gun fight.	
Start Position: Standing at P1, gun held at low ready with three rounds loaded.	
Stage Procedure	Notes
At start, engage T1 with two rounds, then drop T2. Reload and engage T3. Engage the remaining threats from cover at P3 or P4.	Scoring IDPA, Vickers Rounds 17 Min Distance 5 to 10 yds Start - Stop Audible - Last Shot Concealed Carry Yes
T3 is not a disappearing target. All paper threats must be engaged with two rounds and will be scored for the best two hits.	
Note: If you miss T2, you must move to cover at P2 to perform reload.	

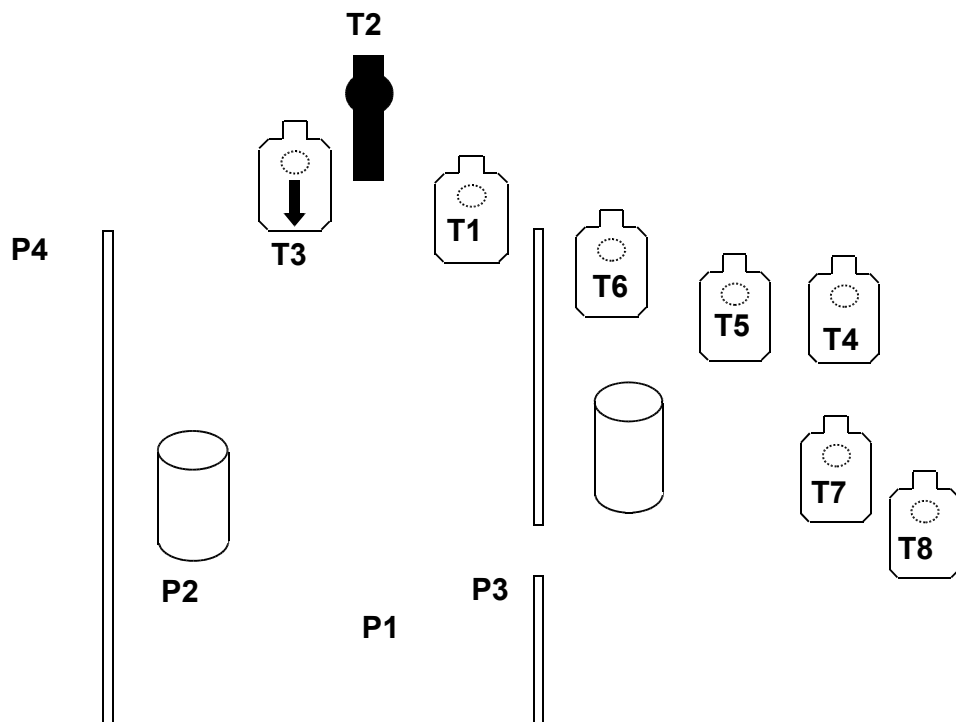

**Take 'em Down**

Ron Holland

Start Position: Standing at P1, butt to barrel facing the wall, holding broom handle in both hands.	
Stage Procedure	Notes
On signal, release the swinger, draw and engage T1 while moving to cover. From cover, engage the remaining targets. All targets will be scored for best two hits.	Scoring Vickers Rounds 12 Minimum Distance 7 to 10 Yds Start - Stop Audible - Last Shot Conceal Carry Yes

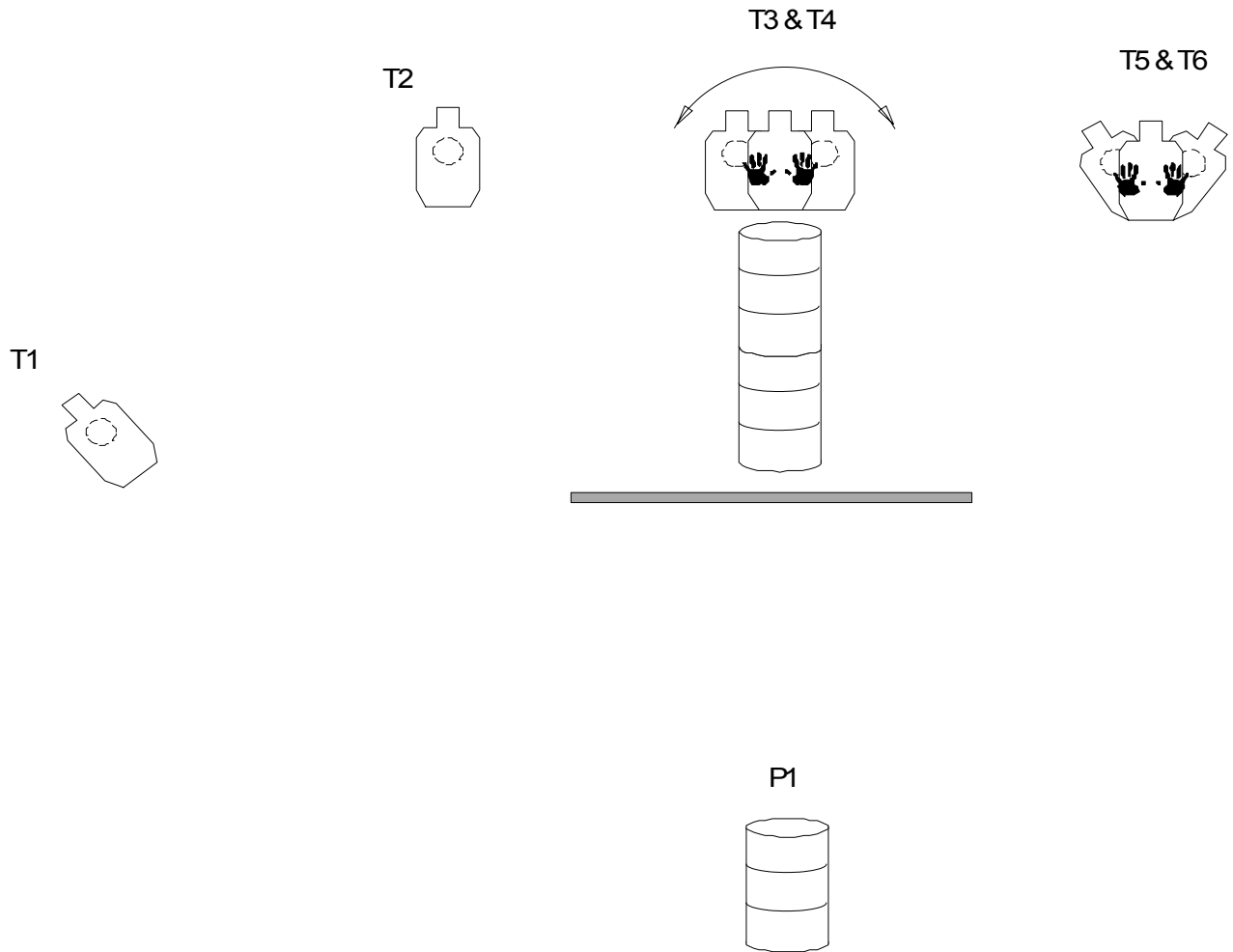

Start Position: Standing at P1, gun holstered, hands naturally at sides.	
Stage Procedure	Notes
At start, drop T1. Engage T2 and T3 in the order of your choice from P1 or while retreating. You may engage the remaining threats from P2 or you may elect to engage T4 – T6 ONLY from P2, then move to P3 and finish. T3 – T8 will be scored for the best two hits. T2 will be scored for two body and one head.	Scoring IDPA, Vickers Rounds 18 Min Distance 3 to 10 yds Start - Stop Audible - Last Shot Concealed Carry Yes

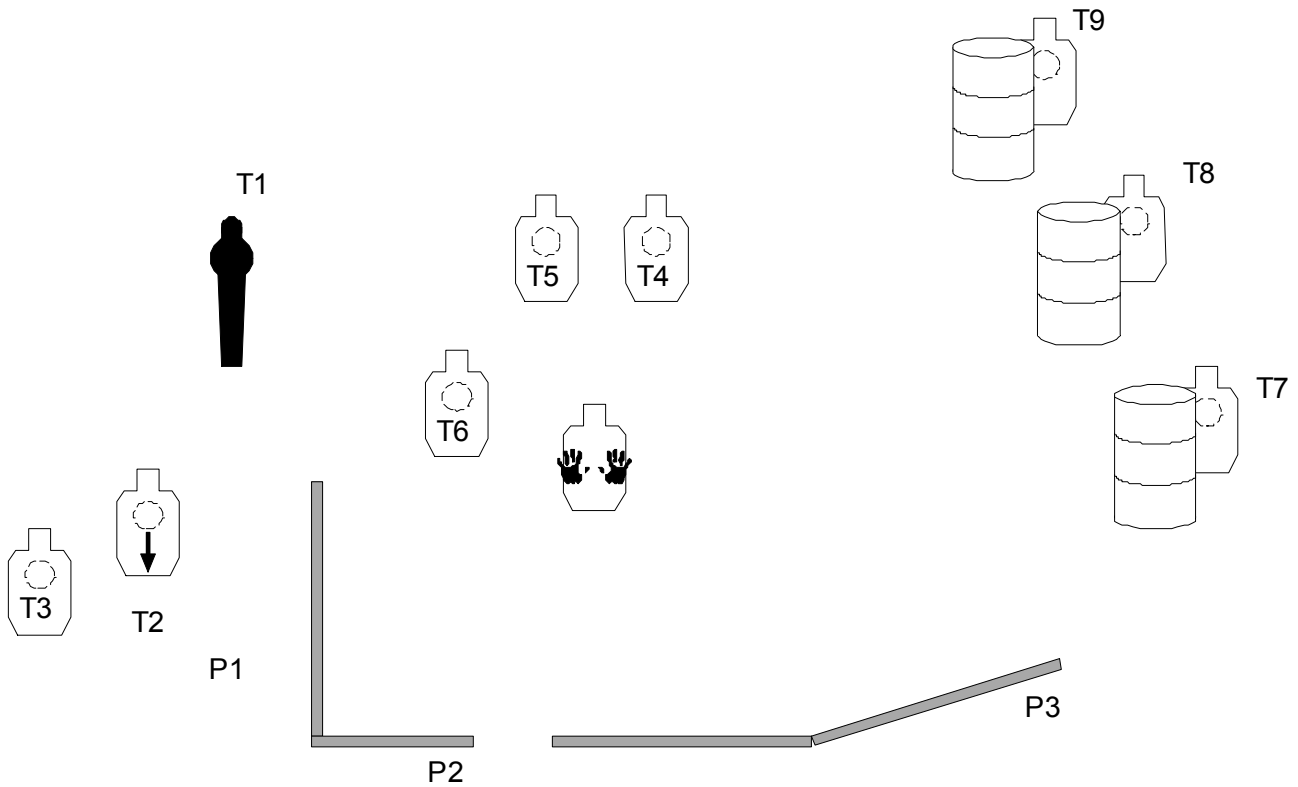

**Take it Back Down**

Joe Day

Start Position: Standing at P1, hands on wall at markers. Body and feet square to wall.	
Stage Procedure	Notes
At start, engage T1 – T3 from P1. Advance to P2 and engage T4 – T6. From P3, engage T7 & T8.	Scoring IDPA, Vickers Rounds 16 Min Distance 3 to 10 yds Start - Stop Audible - Last Shot Concealed Carry Yes
T1 – T7 will be scored for best two hits. T8 will be scored for best two body shots and one head shot.	

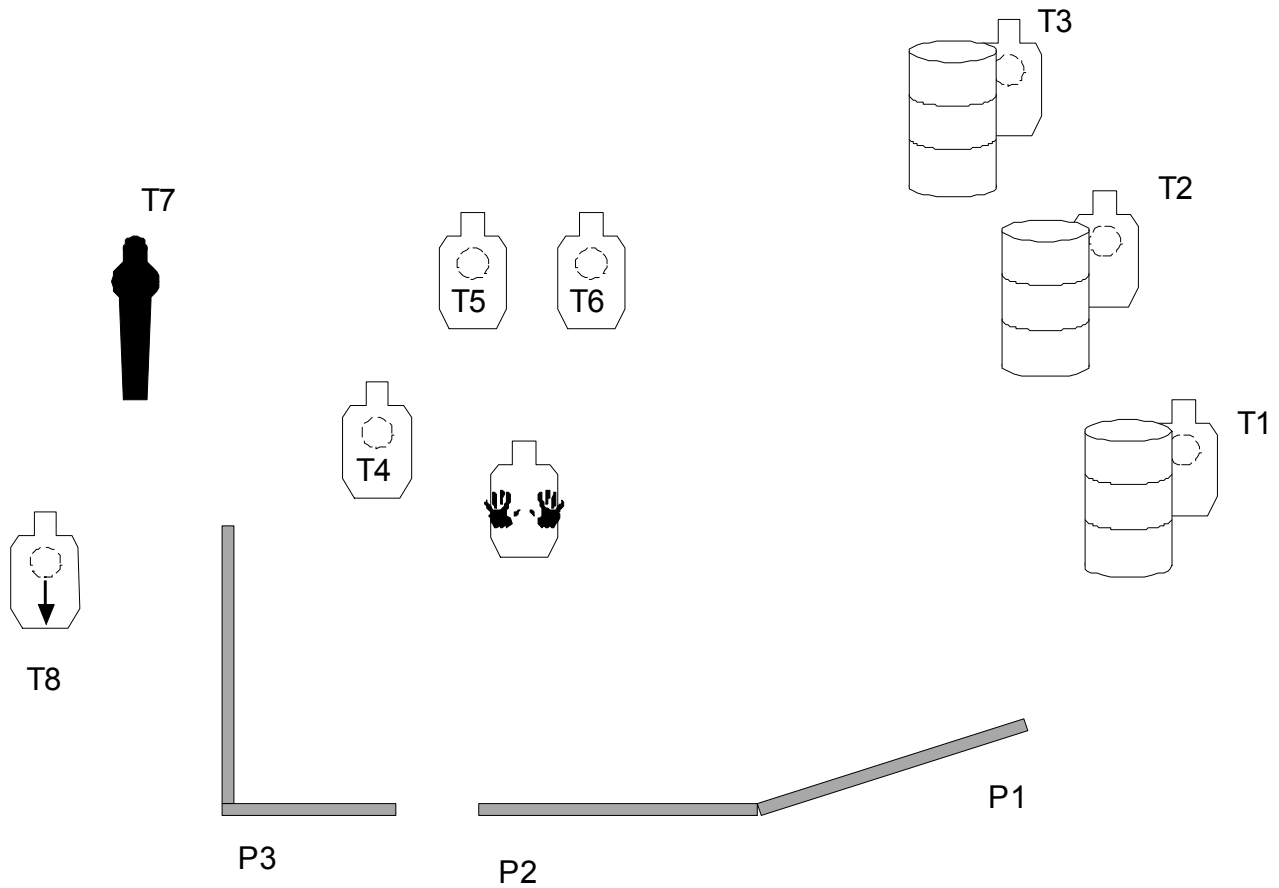

**Rescue 3**

Randy Robinson

Save 3 hostages.	
Start Position: Standing at P1, facing T1 at contact distance hands at sides.	
Stage Procedure	Notes
On signal, engage T1 and T2 with 2 rounds in tactical sequence followed by a head shot each while retreating to P2. Engage T3-T7 with 2 rounds each from cover at P2 or while moving to P3. (Don't get caught in the open with an empty gun). From P3 knock down lollypop plate, T8.	Scoring IDPA, Vickers Rounds 17 Min Distance 3 to 15 yds Start - Stop Audible - Last Shot Concealed Carry Yes

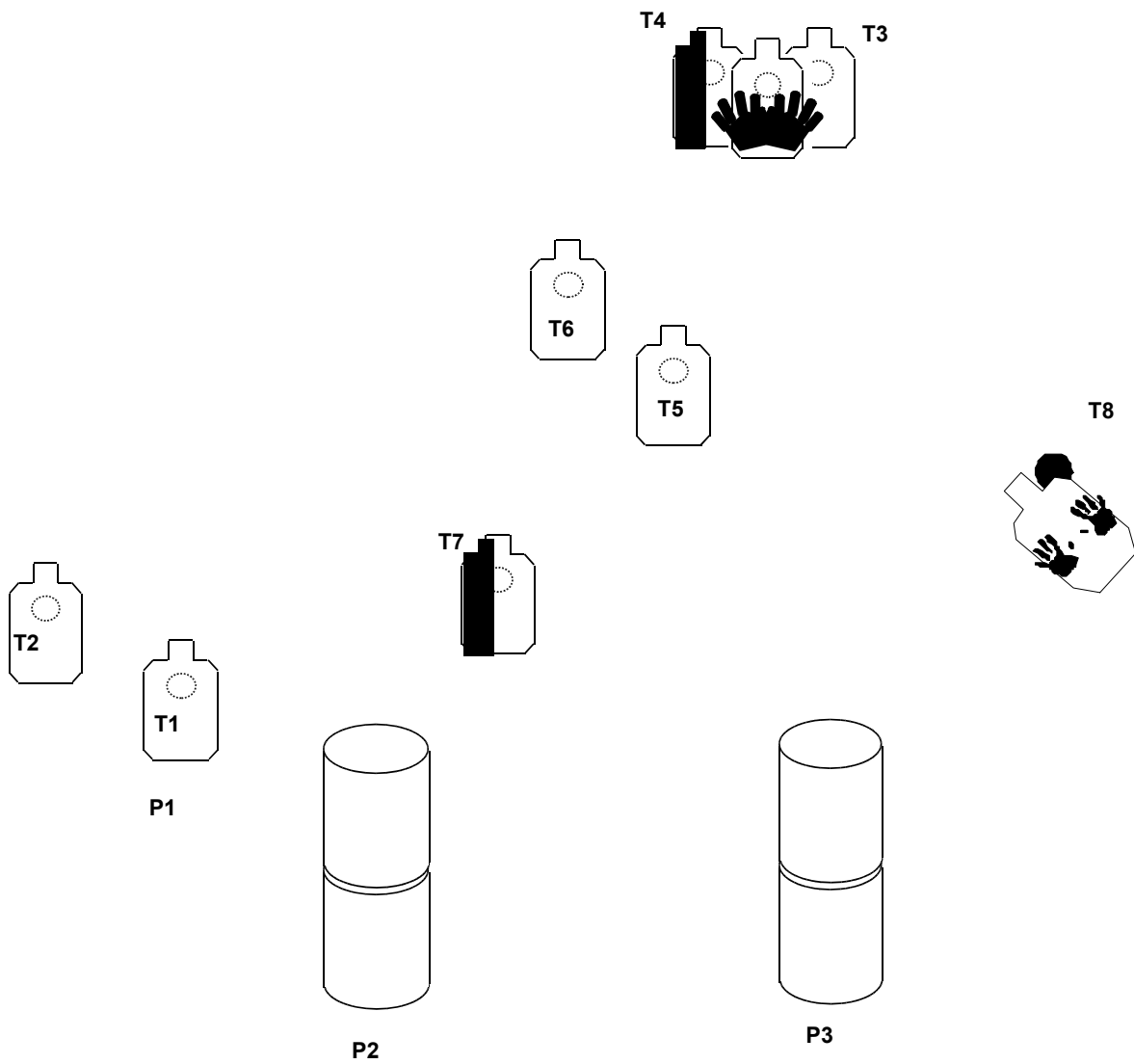

**Run the Gauntlet**

Randy Robinson

Run the gauntlet	
Start Position: Standing at P1, hands at sides	
Stage Procedure	Notes
All paper gets 2 rounds, steel must fall. T4 is a disappearing target. Shoot from cover and/or on the move. All reloads must be performed from cover at P1, P2 or P3.	Scoring IDPA, Vickers Rounds 17 Min Distance 5 to 15 yds Start - Stop Audible - Last Shot Concealed Carry Yes
Targets T1-T3 may not be re-engaged after reaching P2. Targets T4, T5 and S1 may not be re-engaged after reaching P3. Don't get caught in the open with an empty gun.	

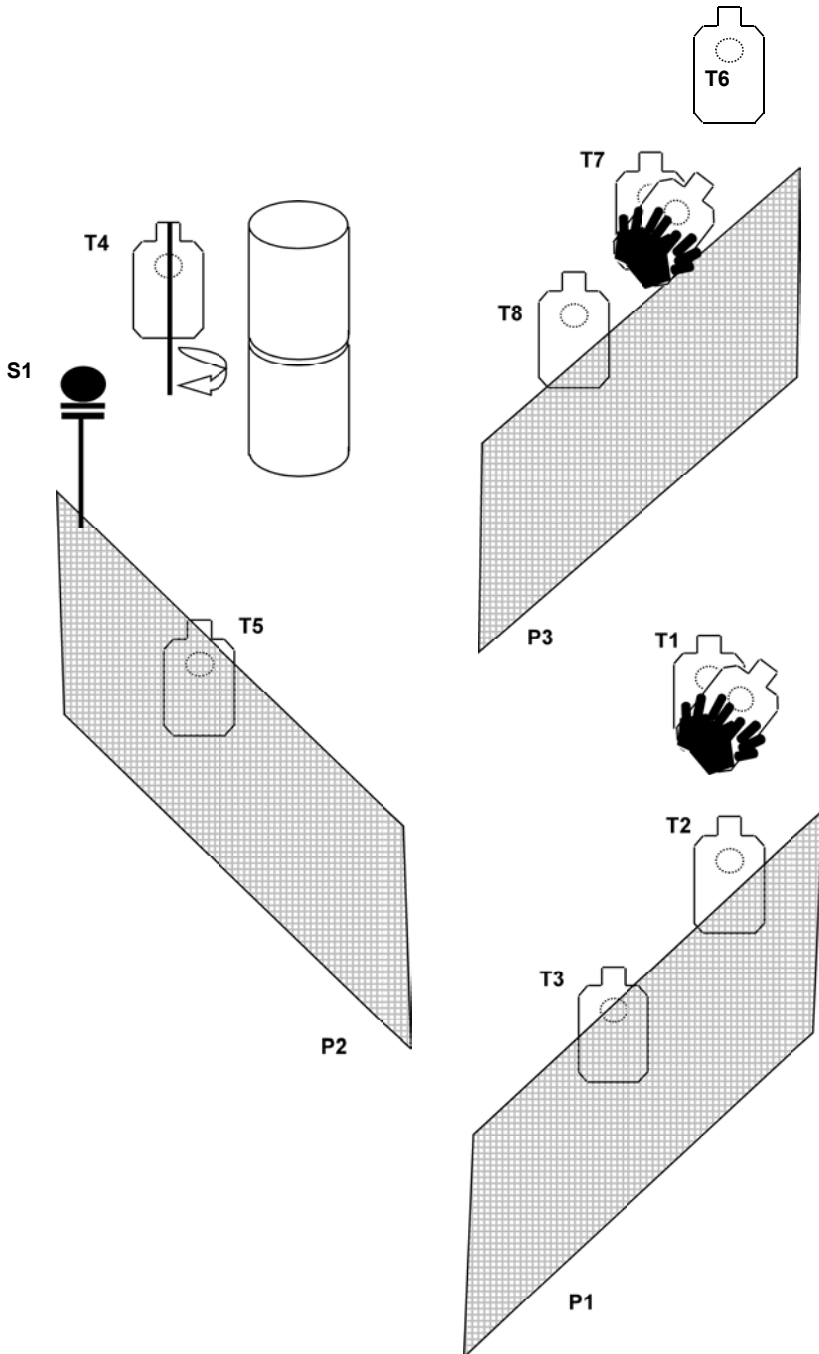

**Tight Shot**

Ron Holland

You are confronted by BGs. You must fend them off with hands before you can deploy your persuader	
Start Position: Fighting stance at P1, hands above waist	
Stage Procedure	Notes
<p>On signal, push the popper down with your strong hand, draw and engage T1. Engage T2 and T3 either while moving or from cover at P2. Engage the remaining threats in tactical priority.</p> <p>Each threat target will be scored for the best two hits.</p>	<p>Scoring Vickers                  Rounds 12 Min                  Distance 4 – 15 Yards                  Start - Stop Audible - Last Shot                  Concealed Carry Yes</p>

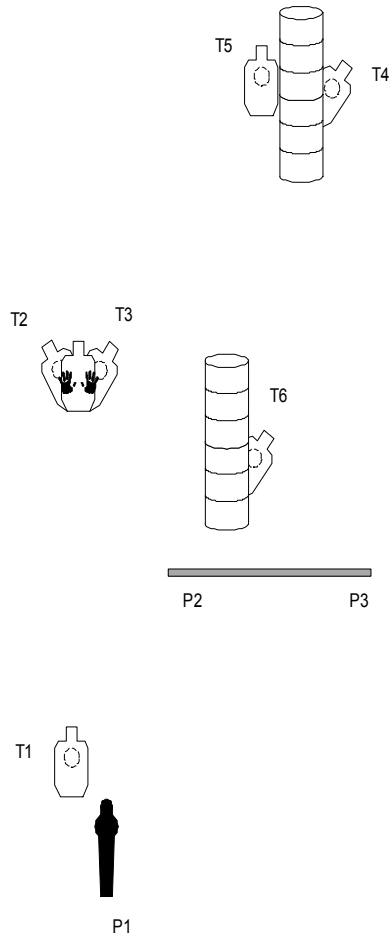

**Clear the House**

Joe Day

Start Position: Standing at P1, phone in strong hand held to strong ear. Face wall with gun holstered.	
Stage Procedure	Notes
<p>At start, engage T1. Then engage T2 – T8 from cover. T7 activates drop-turner T9. You may elect to engage T8 from either P2 or P4. If you do not engage T8 from P2, you must duck under the window to prevent exposure.</p> <p>All paper threats will be scored for the best two hits and all must be engaged a minimum of two shots.</p> <p>T9 may ONLY be engaged from P4.</p>	<p>Scoring IDPA, Vickers</p> <p>Rounds 17 Min</p> <p>Distance 5 to 10 yds</p> <p>Start - Stop Audible - Last Shot</p> <p>Concealed Carry Yes</p>

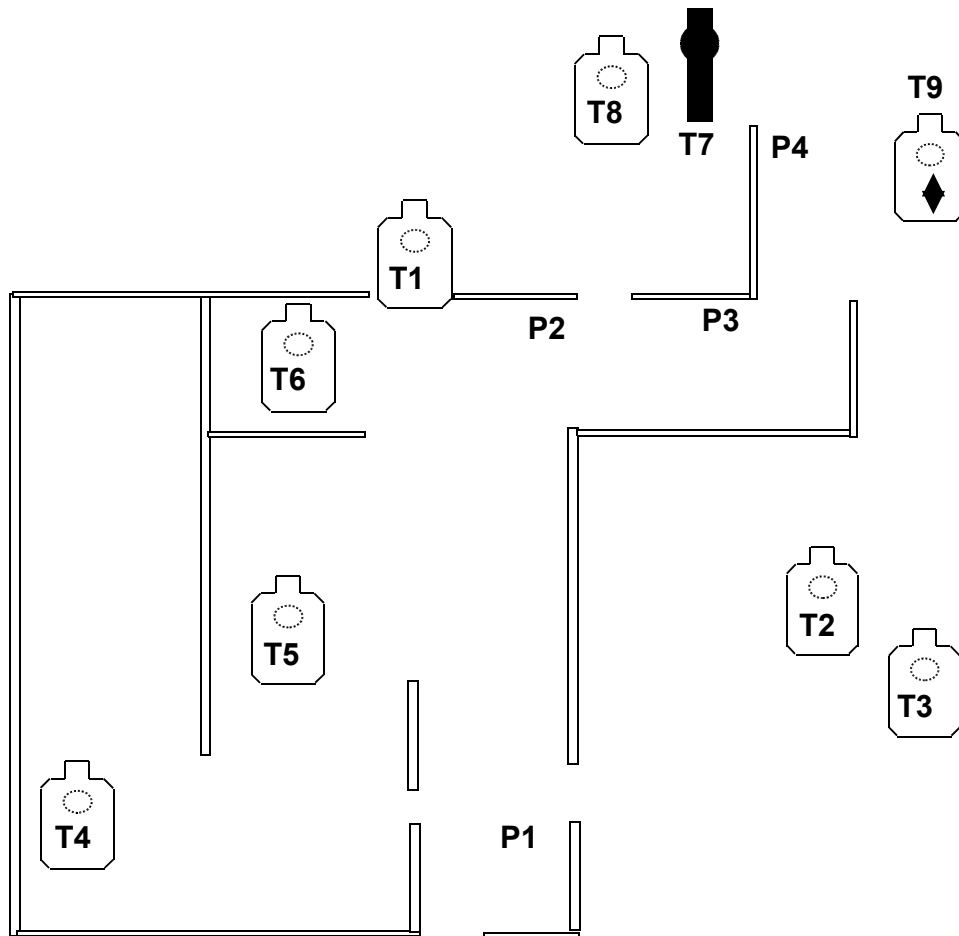

**Careful Shot**

Ron Holland

You are at a social gathering with some wealthy people when some mobsters decide to raid. They eliminate their target first, then decide to roll the other guests. You hear the first shot and go into condition red.

Start Position: Standing at P1, entire body facing the "X". Gun is at low ready, safety on.

Stage Procedure	Notes
<p>All targets will be scored for best three hits. There are no steel targets on this stage, only hard cover. Steel will fall, but you are not required to shoot it and it is not scored.</p> <p>Engage T1 while moving to P2. T2 is engaged from cover at P2, T3 and T4 from cover at P3, T5 from cover at P4, and T6 from cover at P5. You may reload as long as you are not exposed to non-engaged threats.</p>	<p>Scoring IDPA, Vickers</p> <p>Rounds 18 Minimum</p> <p>Distance 5 to 15 Yds</p> <p>Start - Stop Audible - Last Shot</p> <p>Conceal Carry Yes</p>

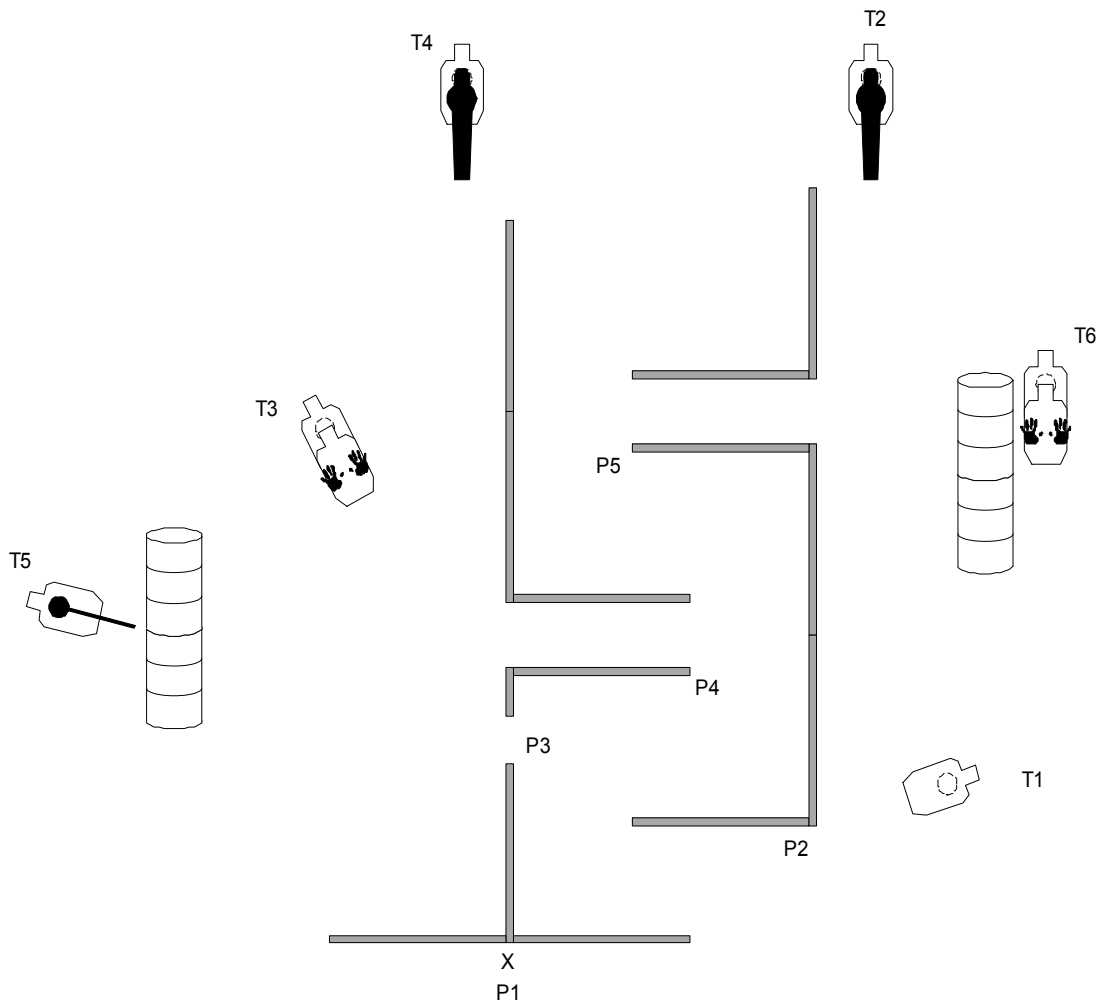

**Accuracy and Timing**

Ron Holland

You are confronted by three gangsters. The front man presses and you kick him down to buy time to get Betsy into the fight. By the time you eliminate the other two, the first rises again.

Start Position: Standing at P1, gun holstered, fighting position facing Popper. T3 framed between fists.

Stage Procedure	Notes
<p>On signal, kick popper down, draw and engage T1 &amp; T2 in tactical sequence. Then engage T3. Movement is optional. From P2, engage T4 until it falls. Then engage the remaining threats in tactical priority.</p> <p>All paper targets will be scored for the best two hits.</p> <p>Note: T3 must be engaged <b>AFTER</b> T1 &amp; T2</p>	<p>Scoring Vickers</p> <p>Rounds 13 Minimum</p> <p>Distance 7 to 12yards</p> <p>Start - Stop Audible - Last Shot</p> <p>Conceal Carry Yes</p>

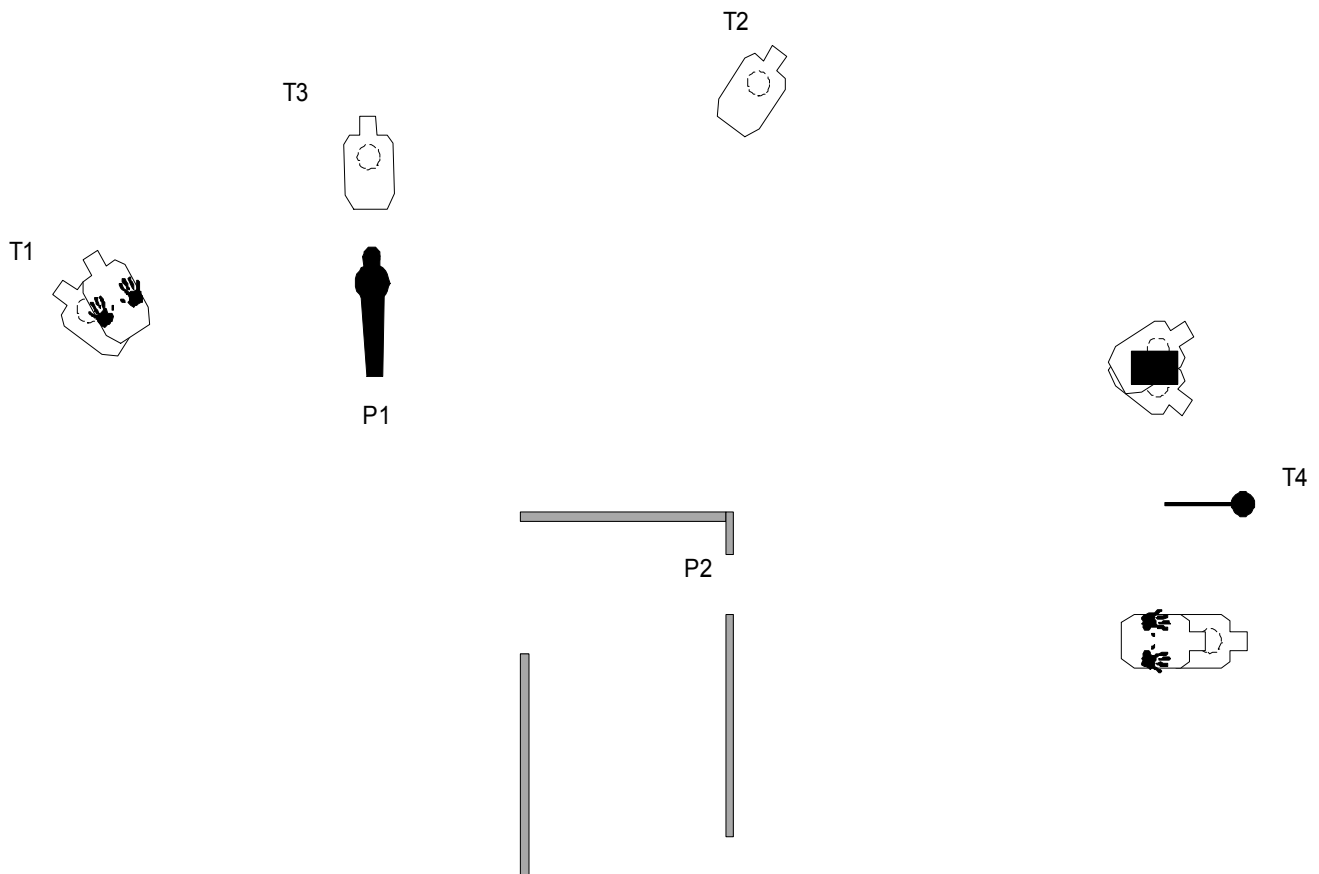

**The Deposit**

Ron Holland

You are on the way to deposit the cash from a small business. You are met by a gang of bad guys. They ask for the money and you place your hand on your gun to let them know you are prepared. They then go for guns.

Start Position: Standing at P1, just behind the marker. Money bag in support hand, gun in holster, hand on gun, preparing to meet the threat. You do not have a clear shot at the nearest threat.

Stage Procedure	Notes
<p>On signal, engage either T1 and T2 in the order of your choice. THEN, engage T3. Firing on the move is optional. From cover at P2, engage three threats. From cover at P3, engage two threats.</p>	<p>Scoring Vickers                      Rounds 15 Minimum                      Distance 3 to 10 Yds                      Start - Stop Audible - Last Shot                      Conceal Carry Yes</p>

